



Release Notes

UNIVERGE® SV8300

R3.5 Software Release

[NEC Corporation of America](#)

6535 N State Highway 161 Irving, Texas 75039 | Phone: 214.262.2000 | Fax: 214.262.2586
www.necunifiedsolutions.com

1. Overview	3
2. New Business Feature	3
2.1 Standard SIP Telephone Support	3
2.1.1 Benefits	9
2.1.2 Required Software and Hardware	9
3. Enhanced Features	10
3.1 Caller ID Sub-Line	10
3.1.1 Benefits	11
3.1.2 Required Software and Hardware	12
3.2 Room Cut-Off Toll Restriction – Guest Room	12
3.2.1 Benefits	12
3.2.2 Required Software and Hardware	12
3.3 Link Re-Connect CCIS	12
3.3.1 Benefits	14
3.3.2 Required Software and Hardware	14
Software	15
Technical Documentation	16

1. Overview

The UNIVERGE SV8300 continues to provide new and enhanced features with the release of 8300 R3.5 series software. R3.5 revision software includes new feature Standard SIP terminals supporting OAI, PMS, SMDR, enhancements including Caller ID Sub-Line, Room Cut-Off Toll Restriction and Link Re-Connect CCIS.

2. New Business Feature

2.1 Standard SIP Telephone Support

This feature allows the UNIVERGE SV8300 to accommodate standard SIP terminals (third-party phones) based on IETF RFC3261 and RFC5359. SIP terminal stations can establish interconnection with other types of stations such as DT300, DT700, Dterm IP and analog stations. The R3 Version License is required to for standard SIP support.



A standard SIP terminal uses two channels.

- SIP Converter Channel (To control SIP messages)
- VoIP Card Channel (To transmit voice RTP)

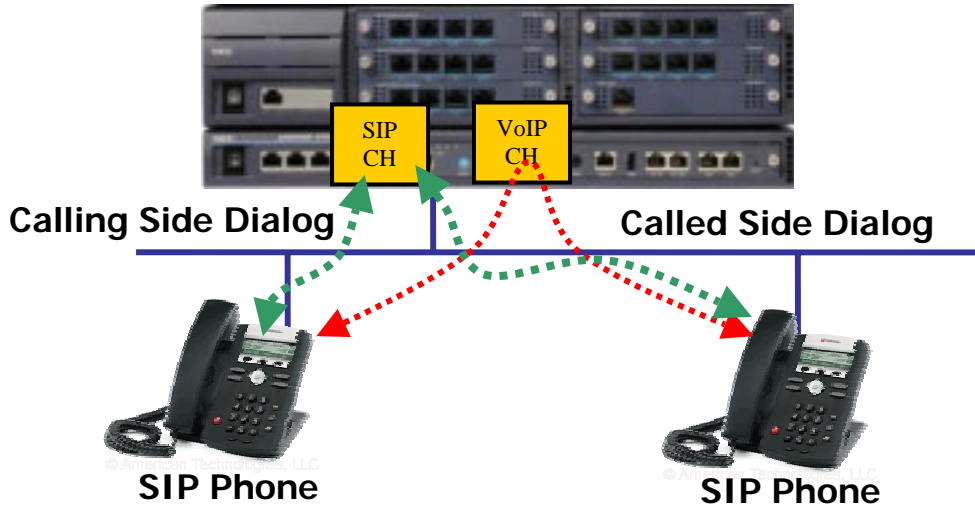

Call Connections Within UNIT 01

		Connection Types (UNIT 01)					
		TDM & Analog	DTERM IP	DT700 Series	Standard SIP Terminal	SIP Trunk	P to P CCIS
Standard SIP Terminal	VoIP Channels (UNIT 01)	1 CH	2 CH	2 CH	2 CH	2 CH	2 CH
	SIP Converter Channels	1 CH	1 CH	1 CH	2 CH	1 CH	1 CH

Call Connections Between UNIT(s)

		Connection Types (UNIT 02 to 50)		
		TDM & ANALOG	Dterm IP	DT700 Series
Standard SIP Terminal	VoIP Channels (UNIT 01)	2 CH	2 CH	2 CH
	VoIP Channels (UNIT 02 to 50)	1 CH	NONE	NONE
	SIP Converter Channels	1 CH	1 CH	1 CH

System Conditions

No.	Item	Data	Remarks
1	Number of standard SIP stations	Max. 512	
2	Accommodated UNIT	UNIT 01 only	
3	Voice Codec	G.711 (64Kbps) G.722 (64Kbps) G.729a (8Kbps)	
4	Payload Size	20ms, 30ms, 40ms	
5	DTMF Relay	Out-Band (RFC2833) In-Band (Voice Pass Through)	
6	SIP FAX Relay	Not Supported	
7	Jitter Buffer	10ms – 300ms	
8	QoS	IP Precedence, Diffserv	
9	PAD	[-16dB] – [+16dB]	
10	Echo Cancelation (EC)	G.168 (up to 64ms), NLP (Non Linear Processor) provided	Set to VoIP DB
11	Silence Suppression	Not Supported	

Supported RFC(s)

RFC	Title	Remark
RFC2327	SDP: Session Description Protocol	Describes multimedia sessions for the purposes of session announcement.
RFC2617	HTTP Authentication: Basic and Digest Access Authentication Status	One of the agreed methods to negotiate credentials with a user (using HTTP protocol)
RFC2833	RTP Payload for DTMF Digits, Telephony Tones and Telephony Signals	Standards-based mechanism used to send DTMF digits in-band (RTP)
RFC3261	SIP: Session Initiation Protocol	SIP Basic
RFC3264	An Offer/Answer model with Session Description Protocol (SDP)	SIP SDP Control
RFC3515	The Session Initiation Protocol (SIP) Refer Method	Attended Transfer
RFC3842	A Message Summary and Message Waiting Indication Event Package for the Session Initiation Protocol (SIP)	Message Waiting Indication
RFC4028	Session Timers in the Session Initiation Protocol (SIP)	Session Timer
RFC5359	Session Initiation Protocol Service Examples	SIPPING 19 Telephony Features

Open Application Interface (OAI) is supported on the standard SIP terminals. (OAI system license is required.)



Property Management System (PMS), Station Message Detail Recording (SMDR) and Message Waiting (MW) is supported on the standard SIP terminals. (PMS system license is required.)



Supported SIPPING 19 Features

Feature	Remarks
Call Hold	Hold tone in the standard SIP terminal is used as a hold tone
Consultation Hold	Hold tone in the standard SIP terminal is used as a hold tone
Transfer - Unattended	
Transfer - Attended	
Call Forwarding Unconditional	Feature Access Code - All Calls feature.
Call Forwarding - Busy	Feature Access Code - Busy Line feature.
Call Forwarding - No Answer	
3-way Conference - Third Party is Added	32 Party or Multimedia Conference feature.
3-way Conference - Third Party Joins	It is possible by the PBX Conference feature.
Call Management (Incoming Call Screening)	Route/trunk restriction, Class of Service Individual for this function.
Call Management (Out. Call Screening)	Route/trunk restriction, Class of Service Individual for this function.
Call Park	It is possible to retrieve a Call Park with Feature Access Code feature.
Call Pickup	Feature Access Code Call Pickup feature.
Click to Dial	Feature between SIP Terminal and Application on PC

The following SIP Devices have been basically tested on the SV8300 in NEC lab.

SIP Devices	SIP Devices
Polycom Sound Station 500/600 Polycom SoundPoint IP301 Polycom SoundPoint IP320 Polycom SoundPoint IP330 Polycom SoundPoint IP501 Polycom SoundPoint IP650 Polycom SoundStation IP6000 Polycom SoundStation IP7000	TeleMatrix 3300IP-TRM TeleMatrix 3300IP-MWD TeleMatrix IP550 TeleMatrix 9600/9602IP AASTRA 9112i AASTRA 9133i AASTRA 9480i
Teledex SIP ND1210 POE Teledex SIP ND2210S POE	GrandStream BT-200 GrandStream GXP-2000

2.1.1 Benefits

- Investment Protection and Managed Evolution
- Building on existing infrastructure, making old and new work together.
- Provides Telephony Features to SIP Endpoints
- SIP Phones and Applications are available from large variety of manufacturers.

2.1.2 Required Software and Hardware

- R3 Version License
- R3.5 D2 System Software
- SIP License
- Port License
- OAI License (optional; if required OAI is used)
- PMS License (optional; required if PMS is used)
- IP-PAD License (if IP-PAD ch needs to be increased)

3. Enhanced Features

3.1 Caller ID Sub-Line

This enhancement provides caller ID on the LCD of DT300/700 display terminals on ringing and call termination to a sub-line. The same sub-line can appear on hundreds of phones and displays the CID Name and Number to all terminals at the same time. Caller ID Display is automatically provided on ringing and call termination, no manual operation is required.

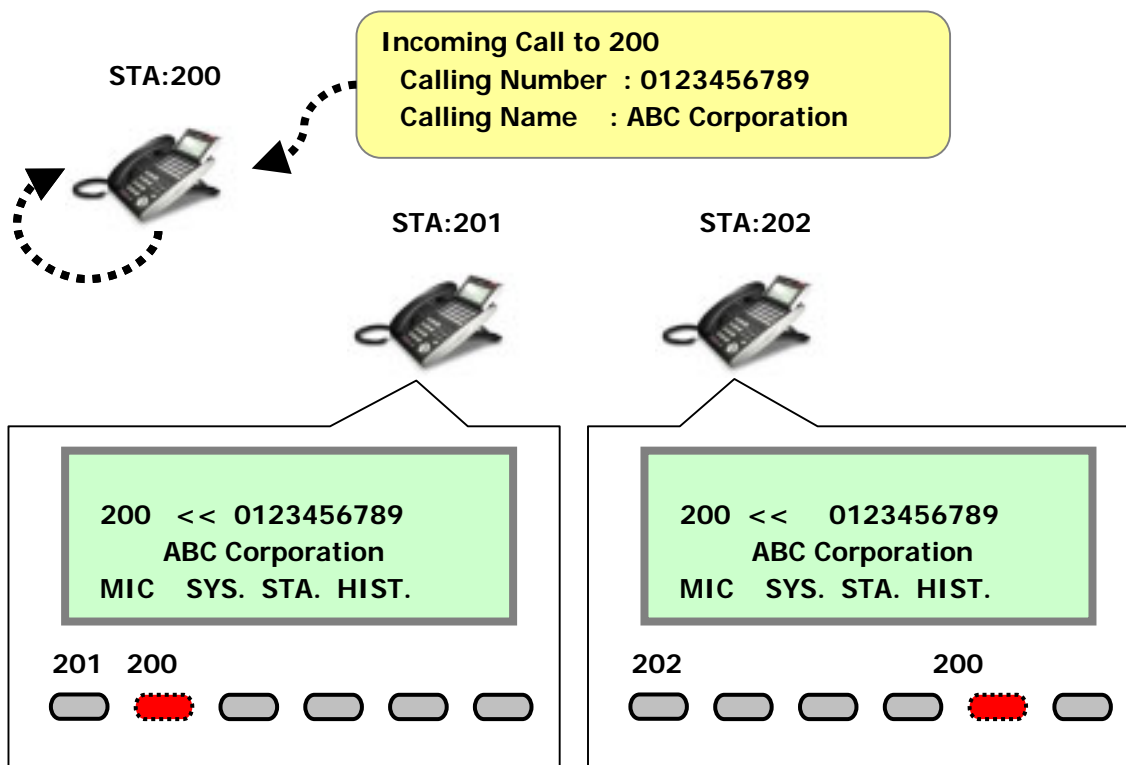

Following are examples of Caller ID Display for sub-line..

(1) Call rings to sub-line 201.
→ Caller ID of incoming call to sub-line 201 is displayed.

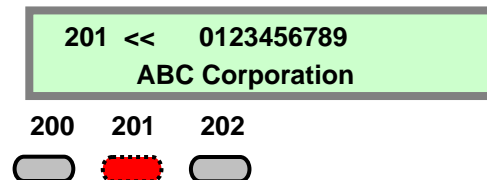

(2) Another call rings to sub-line 202.
→ The display does not change.
(The first caller ID display has priority.)

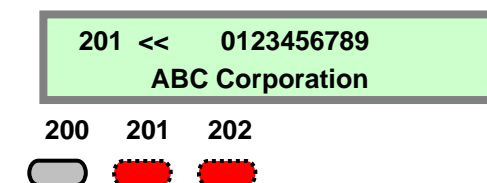

(3) The incoming call to 201 is answered at another terminal that has sub-line 201 appearance.
→ The display changes to

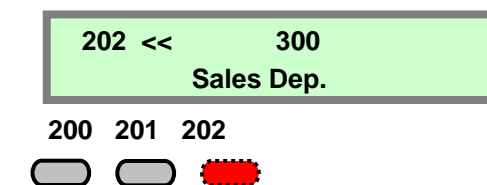

(4) The incoming call to sub-line 202 is answered at another terminal that has sub-line 202 appearance.
→ Display returns to idle state

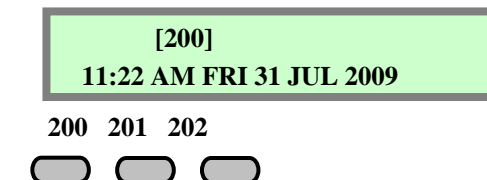

R3 Version License is required for Caller ID Sub-line. NEC terminals that support Caller ID Sub-line are DT300/700, Dterm 80/85 (series i Digital), Dterm 85 IP (series i IP), Dterm 70/75, (series E Digital) Dterm 75 IP (series E IP), SP30, and MH240.

3.1.1 Benefits

- Receptionist and secretaries can answer calls for a department when the destination station does not answer the call and automatically see the CID on destination stations sub-line that appears on their terminal

3.1.2 Required Software and Hardware

- R3 Version License
- R3.5 D2 System Software

3.2 Room Cut-Off Toll Restriction – Guest Room

This feature allows the Hotel/Motel Front Desk Instrument or Property Management System (PMS) to set a trunk restriction class when checking in the guest. By setting the room to Room Cut-Off only local calls are allowed, or only 911 calls are allowed etc.. The trunk restriction class is set in system data programming.

3.2.1 Benefits

This allows the front desk attendant to restrict calls that would generate telephone charges for a cash paying guest.

3.2.2 Required Software and Hardware

- R3 Version License
- PMS License (optional; required if PMS is used)

3.3 Link Re-Connect CCIS

This feature provides the system connected to CCIS network with the capability to release the redundant CCIS link connection and re-connect the link within the system.

The link re-connect enhancement is provided for the following call types:

A station call over CCIS is transferred or forwarded to another station or trunk within the same office as the call originating station.

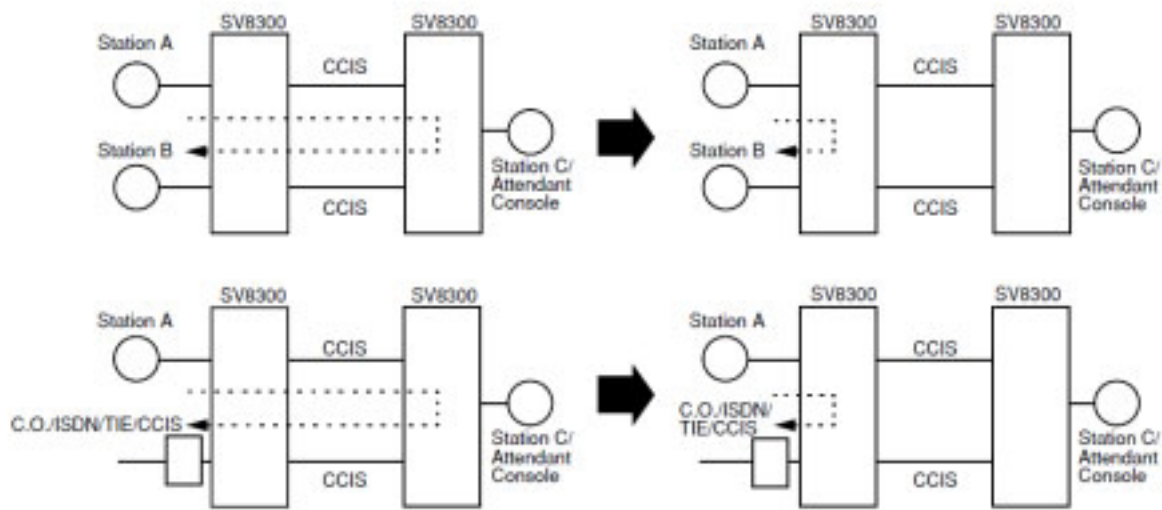

A trunk call (C.O./ISDN/TIE/CCIS) over CCIS is transferred or forwarded to another station or trunk within the same office as the original incoming trunk.

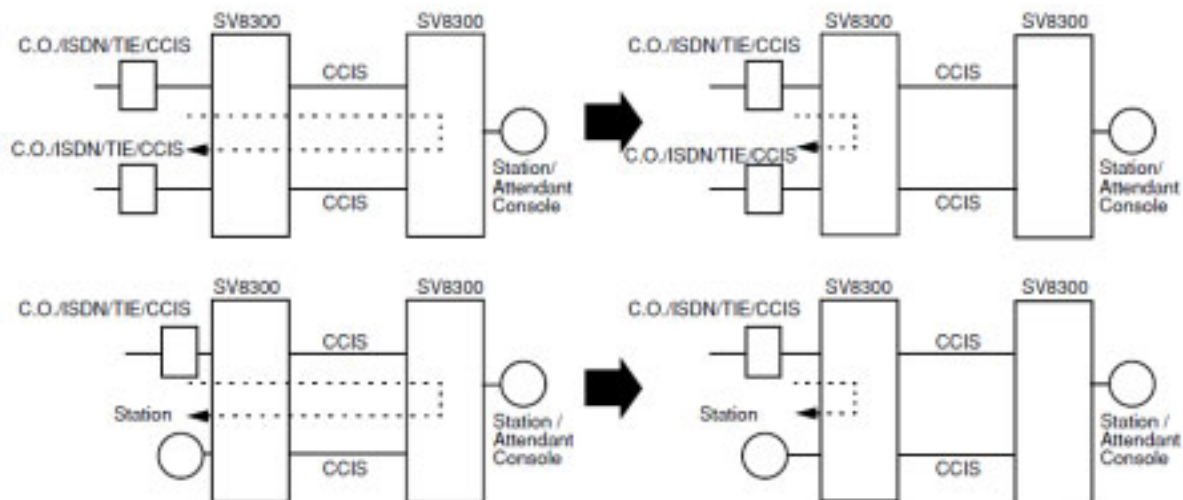

A trunk call (C.O./ISDN/TIE/CCIS) over CCIS is transferred or forwarded to the VRS for Delay Announcement- UCD within the same office as the original incoming trunk.

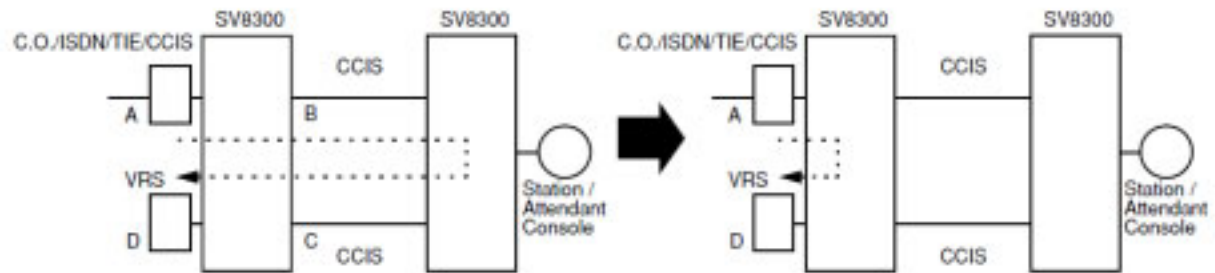

3.3.1 Benefits

- Link Re-Connect provides for efficient use of the CCIS links.

3.3.2 Required Software and Hardware

- R3 Version License Software
- R3.5 D2 System Software

Software

Part Number	Description	Comments
Software - New and Enhancement		
670899	LS-SYS-R3-LIC	R3 Version License
670760	LS-EXT-STD-SIP-LIC	Standard SIP license, one required for each endpoint.

NOTE: These release notes are provided as a quick reference of R3.5 enhancements and may not cover all service and operation conditions. The UNIVERGE SV8300 Features and Specifications document should be referenced for detailed information about each feature and enhancement before discussion and implementation.

Technical Documentation

Description	Revision
UNIVERGE SV8300 System Hardware Manual	2.0
UNIVERGE SV8300 Command Manual	4.0
UNIVERGES SV8300 Programming Manual (for 8300R3.5)	1.0
UNIVERGE SV8300 Networking Manual	4.0
UNIVERGE SV8300 System Manual	4.0
UNIVERGE SV8300 PC Programming Manual	3.0
UNIVERGE SV8300 System Data Programming	3.0
UNIVERGE SV8300 System Maintenance Manual	3.0
UNIVERGE SV8300 Feature & Specification (for 8300R3.5)	1.0
UNIVERGE SV8300 Business/Hotel Feature & Specification	3.0
UNIVERGE SV8300 SMDR-MCI-PMS Specification	3.0
UNIVERGE SV8300 ISDN/Q-SIG Feature & Specification	3.0
UNIVERGE SV8300 CCIS Feature & Specification	3.0
UNIVERGE SV8300 WCS Feature & Specification	3.0
UM8000 Installation Guide	2.0
InRouter Configuration Guide	1.0
PoE Gigabit Switch Configuration Guide	2.0
SV8300 Parts & Price Book	5.0